

# ICCS – Intelligent Control and Command Systems

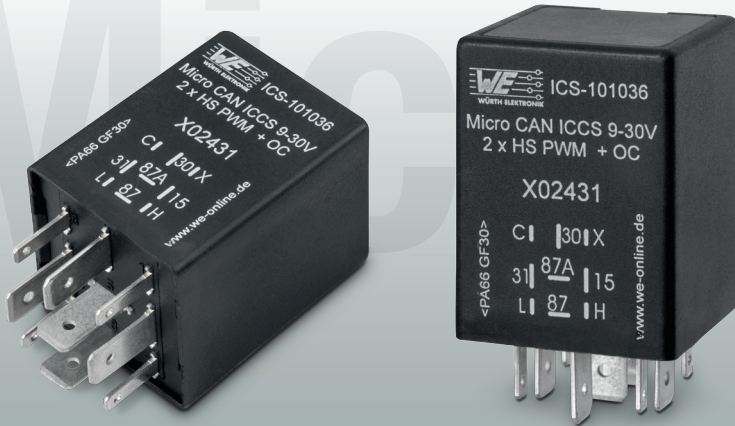

## Micro CAN

**ICCS Micro CAN** – Standalone module or an extension module to existing CAN bus systems. The smallest freely programmable control system with CAN bus communication offers the compact relay design versatility.

Digital information and analogue voltages can be detected and processed. Alternatively there are two overload protected high side outputs with PWM possibility or one relay output available.

### Applications

- Compact graphically programmable control unit for mobile applications
- Input and output extensions for CAN bus systems
- Connection of binary and analogue sensors via the CAN bus

### Technical data

General information	
Connector	9 Pins DIN
Dimensions	30 x 30 x 40 mm
Weight	~35 g (High side), ~45 g (Relay)
Operating temperature	-40 °C to 85 °C (no full load at 85 °C)
Storage temperature	-40 °C to 85 °C
Ingress protection	IP 53
EMC	E1
Operating voltage Vsupply	9 to 30 V DC (High side version) 12 or 24 V DC (Relay version)
Pre-fusing	up to 15 A (depending on load)
Current consumption	30 mA
Processor type	Freescale HCS08 DZ60
Clock frequency	40 MHz
Flash memory	60 kB
RAM	4 kB
EEPROM	1 kB available for graphical programming

### CAN Bus

acc. ISO 11898-2	High speed
acc. CAN 2.0 B	29 Bits extended address identifier
acc. CAN 2.0 A	11 Bits address identifier
Baud rate	20 kBit/s to 1000 kBit/s (125 kBit/s default value)

### Inputs / outputs

2	Analogue inputs	0-11.4 V DC 12 Bits
2	Digital outputs Relay output	High side outputs max 5 A OR Changeover relay 10 A/15 A
1	Open collector output or Analogue input	max 2 W OR 0-11.4 V DC 12 Bit

### Inputs / outputs details

#### Analogue inputs

Input voltage max	Vsupply
Measuring range	0-11.4 V DC
Resolution	12 Bit
Input resistance	22.6 kΩ
Input frequency	max 100 Hz

#### Digital outputs

Load current High side version	max 3.5 A (2.5 A @ 80 °C) max 5 A (load only on one channel)
Load current Relay version	10/15 A (O/C)

#### PWM outputs

PWM frequency	max 1 kHz
Duty cycle	0 to 100 %
Resolution	0.1 %
Load current	max 3 A

Every analogue input is also usable as a digital input in the programming software

# ICCS Micro CAN



## Hardware Map

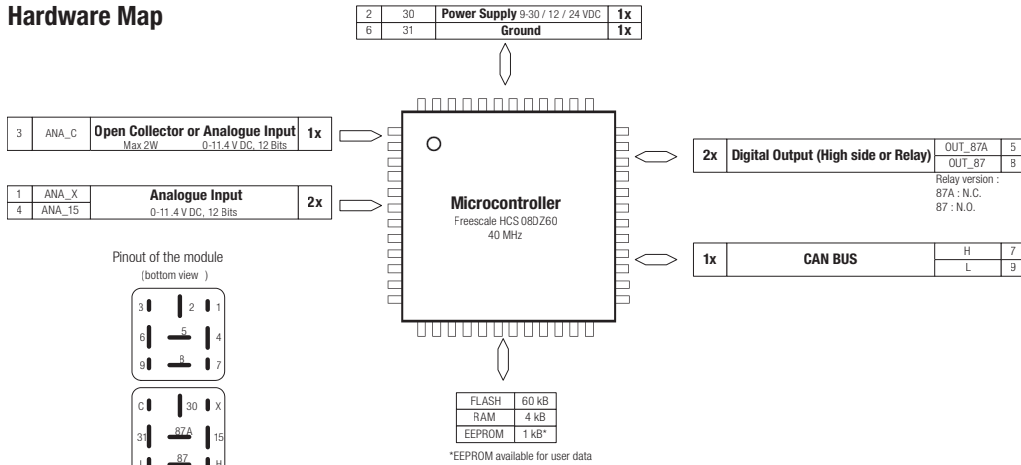

## High side version (S1)

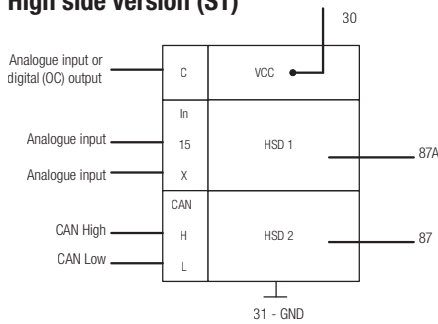

## Relay version (S2)

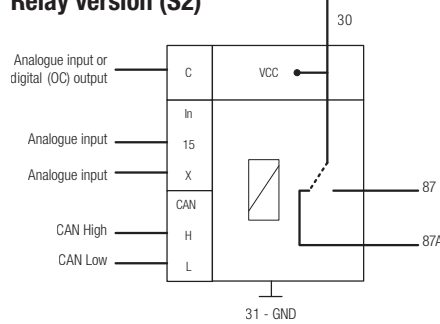

## Relay version (S3)

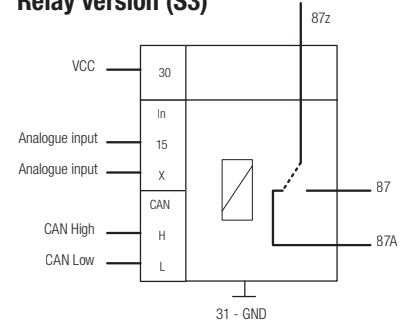

## Pin assignment

Connector Micro CAN		
Pin	Description	Function
1	X	Analogue input 0-11.4 V
2	30	Vcc Main Power Supply 9-30 V/12 V/24 V
3	C	Analogue input 0-11.4 V or Open collector output
4	15	Analogue input 0-11.4 V
5	87 A	Digital output (High side)/Relay output N.C.
6	31	Ground
7	H	CAN Bus High
8	87	Digital output (High side)/Relay output N.O.
9	L	CAN Bus Low

## Order information

Available references	Part number WE ICS
Micro CAN ICCS S1 9-30 V 2 x HS PWM + OC	ICS-101036
Micro CAN ICCS S2 12 V + OC	ICS-100513
Micro CAN ICCS S3 12 V	ICS-98027
Micro CAN ICCS S2 24 V + OC	ICS-100478
Micro CAN ICCS S3 24 V	ICS-100869
Micro CAN ICCS S3 24 V + CAN resistor 120 Ω	ICS-100950

## Dimensions



## Attention:

The pin assignment for this module is different.  
S1 (30) = S3 (87z)  
S1 (C) = S3 (30)

For more information visit us at [www.we-online.com](http://www.we-online.com) or call +49 7940 9810-0.

## Würth Elektronik ICS GmbH & Co. KG Intelligent Power & Control Systems

Gewerbepark Waldzimmern  
Würthstraße 1  
74676 Niedernhall · Germany  
Tel. +49 7940 9810-0  
Fax +49 7940 9810-1099  
ics@we-online.de  
www.we-online.com

This item is a standard product, please consider the relevant datasheet notes.  
The user is responsible for the product's functionality in its purposed system environment.