

ICCS – Intelligent Control and Command Systems



CAN I/O & 22P

ICCS CAN I/O-Series – Graphically programmable mini control system for mobile applications or as an extension to existing CAN systems.

Different designs offer flexible connection and installation possibilities: The variant ICCS-22P is suitable for mounting directly on a PCB. The CAN I/O, protected in a plastic housing, can be wired up with the mini-fit connector system directly to the harness. Through the encasing of the electronics in a compact plastic housing with a sealed connector (IP68) the variant CAN I/O Waterproof is suitable for use in harsh environments. Digital information, analogue voltages, currents and signal frequencies can be detected and processed. Optional variants with 5V reference voltage and RS232/RS485 communication interfaces are available.

Applications

- Input and output extensions for CAN bus systems
- Analogue sensor to CAN module
- Graphically programmable control unit for mobile applications
- Connection of binary and analog sensors via the CAN bus

Technical data

General information	
Connector	Molex Mini Fit 22 Ways
Dimensions	95 x 74 x 33 mm (CAN I/O)
	85 x 62 x 24 mm (22P)
Weight	~75g (CAN I/O) ~95g (22P)
Operating temperature	-40 °C to 85 °C (no full load at 85 °C)
Storage temperature	-40 °C to 85 °C
Ingress protection	IP 23 [std.] – IP 53 [opt.] (CAN I/O)
	IP 53 (22P) – IP 67 (CAN I/O WP)
EMC	E1
Operating voltage Vsupply	9 V to 30 V DC
Pre-fusing	10 A / block
Current consumption	30 mA
Sleep mode consumption	500 µA
Processor type	Freescall HCS08
Clock frequency	40 MHz
Flash memory	60 kB
RAM	4 kB
EEPROM	1 kB available for graphical programming

CANBus

acc. ISO 11898-2	High speed
acc. CAN 2.0 B	29 Bits extended address identifier
acc. CAN 2.0 A	11 Bits address identifier
Baud rate	20 kBit/s to 1000 kBit/s (125kBit/s default value)

Inputs/outputs overview

6	Analogue inputs	5 x 0-11.4 V DC 12 Bit 1 x 0-33.67 V DC 12 Bit
1	Activation pin	KL15 Wake-up Input
6	Analogue inputs or Digital outputs	0-11.4 V DC 12 Bit High side outputs max 2 A
2	Digital inputs or Digital outputs	Switch on/switch off level: 7 V / 4 V DC High side outputs max 2 A

Inputs/outputs details

Analogue inputs

Input voltage max	Vsupply
Measuring range	0-11.4 V DC / 0-33.67 V DC
Resolution	12 Bit
Input resistance	22.6 kΩ
Input frequency	max 100 Hz (0-11.4 V DC)

Digital inputs

Input voltage	0 V to Vsupply
Switch-on level	7 V DC
Switch-off level	4 V DC
Input resistance	22.6 kΩ (66.6 kΩ for KL15)
Input frequency	max 100 Hz

Digital outputs

Load current	High side max 2 A Diagnostic current sense
--------------	---

PWM outputs

PWM frequency	ICS-97191 and ICS-101976 only max 1 kHz
Duty cycle	0 to 100 %
Resolution	0.1 %
Load current	max 1 A

* Every analogue input is also usable as a digital input in the programming software.

ICCS CAN I/O & 22P



Hardware Map

- **ICS-95065:** ICCS CAN I/O Hardware-Bootloader
- **ICS-95114:** ICCS CAN I/O Software-Bootloader
- **ICS-97212:** ICCS CAN I/O Software-Bootloader
with Reference Voltage 5 V
- **ICS-100514:** 22P CAN Controller

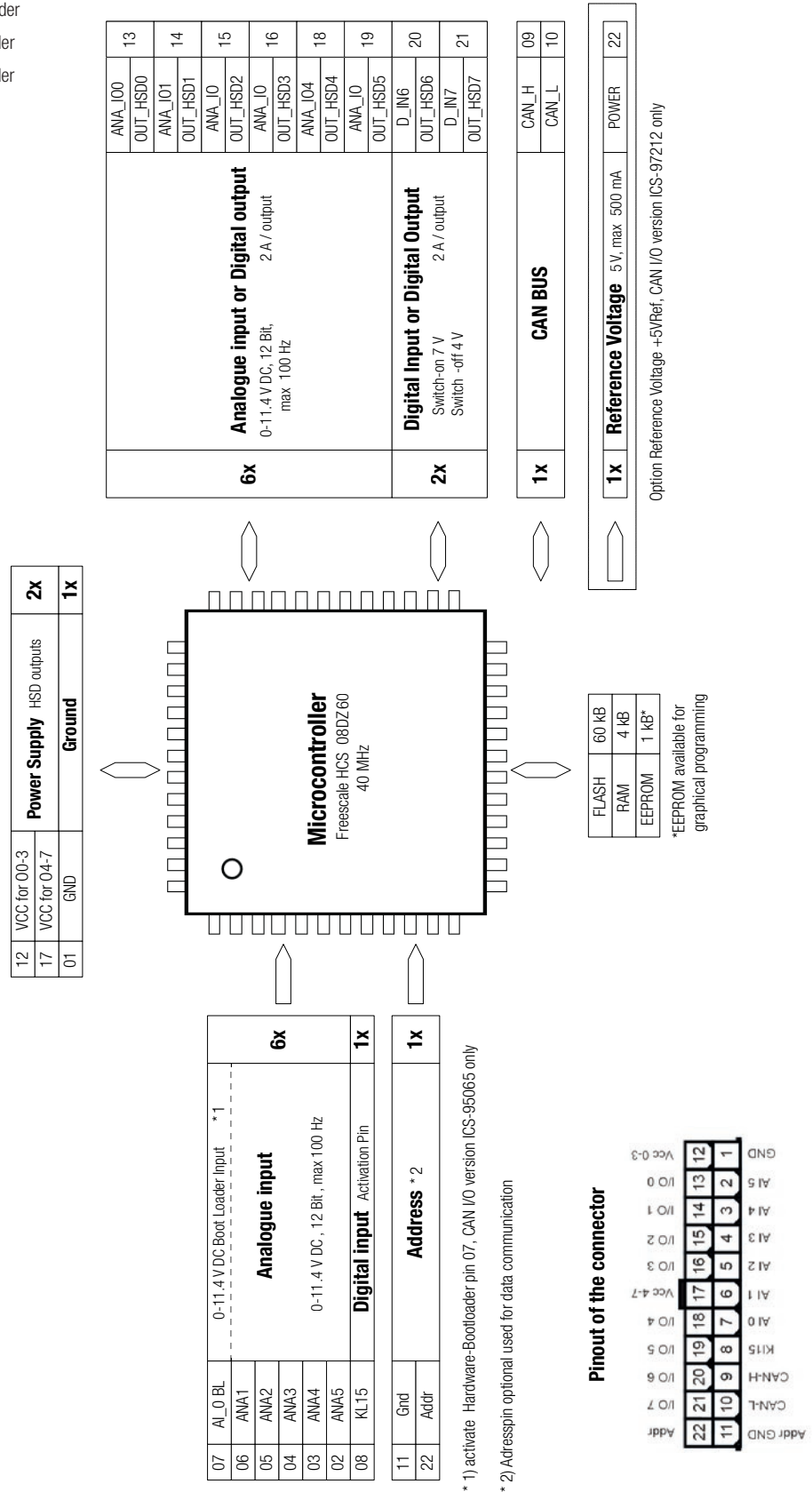

ICCS CAN I/O & 22P



Pin assignment

Connector ICS-95065, ICS-97212, ICS-95114, ICS-100514		
Pin	Description	Function
1	GND	Ground
2	ANA5	Analogue input 0-30 V
3	ANA4	Analogue input 0-10 V
4	ANA3	Analogue input 0-10 V
5	ANA2	Analogue input 0-10 V
6	ANA1	Analogue input 0-10 V
7	ANA0	Analogue input 0-10 V (BL) *1
8	KL15	Activation Pin
9	CAN H	CAN Bus High
10	CAN L	CAN Bus Low
11	Addr GND	Address GND
12	VCC for 00-3	Power Supply HSD output 0-3
13	ANA_I00	Analogue input 0-10 V
	OUT_HSD0	Digital output
14	ANA_I01	Analogue input 0-10 V
	OUT_HSD1	Digital output
15	ANA_I02	Analogue input 0-10 V
	OUT_HSD2	Digital output
16	ANA_I03	Analogue input 0-10 V
	OUT_HSD3	Digital output
17	VCC for 04-7	Power Supply HSD output 4-7
18	ANA_I04	Analogue input 0-10 V
	OUT_HSD4	Digital output
19	ANA_I05	Analogue input 0-10 V
	OUT_HSD5	Digital output
20	D_IN6	Digital input
	OUT_HSD6	Digital output
21	D_IN7	Digital input
	OUT_HSD7	Digital output
22	Addr	Single wire address

*1) Activationpin for Bootloader, version ICS-95065 only

Connector module

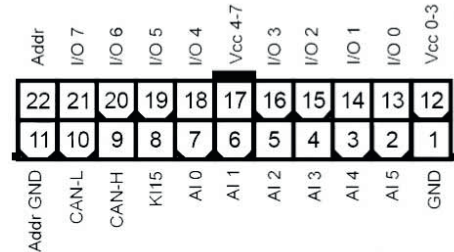

Dimensions

Wire harness version i.e. CAN I/O

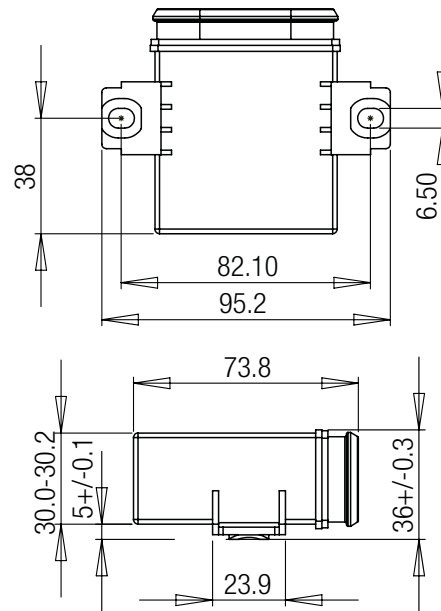

PCB mountable version i.e. 22P

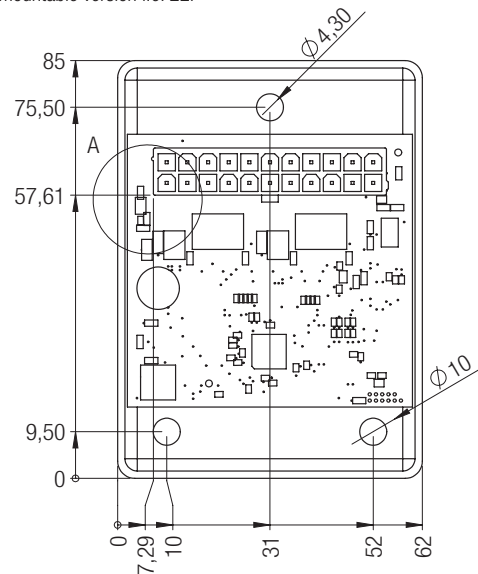

ICCS CAN I/O & 22P



Hardware Map

- **ICS-100710:** ICCS CAN I/O Software-Bootloader
Diode on PWM-output
- **ICS-97191:** ICCS CAN I/O Software-Bootloader
2 x RPM & 6 x PWM-output

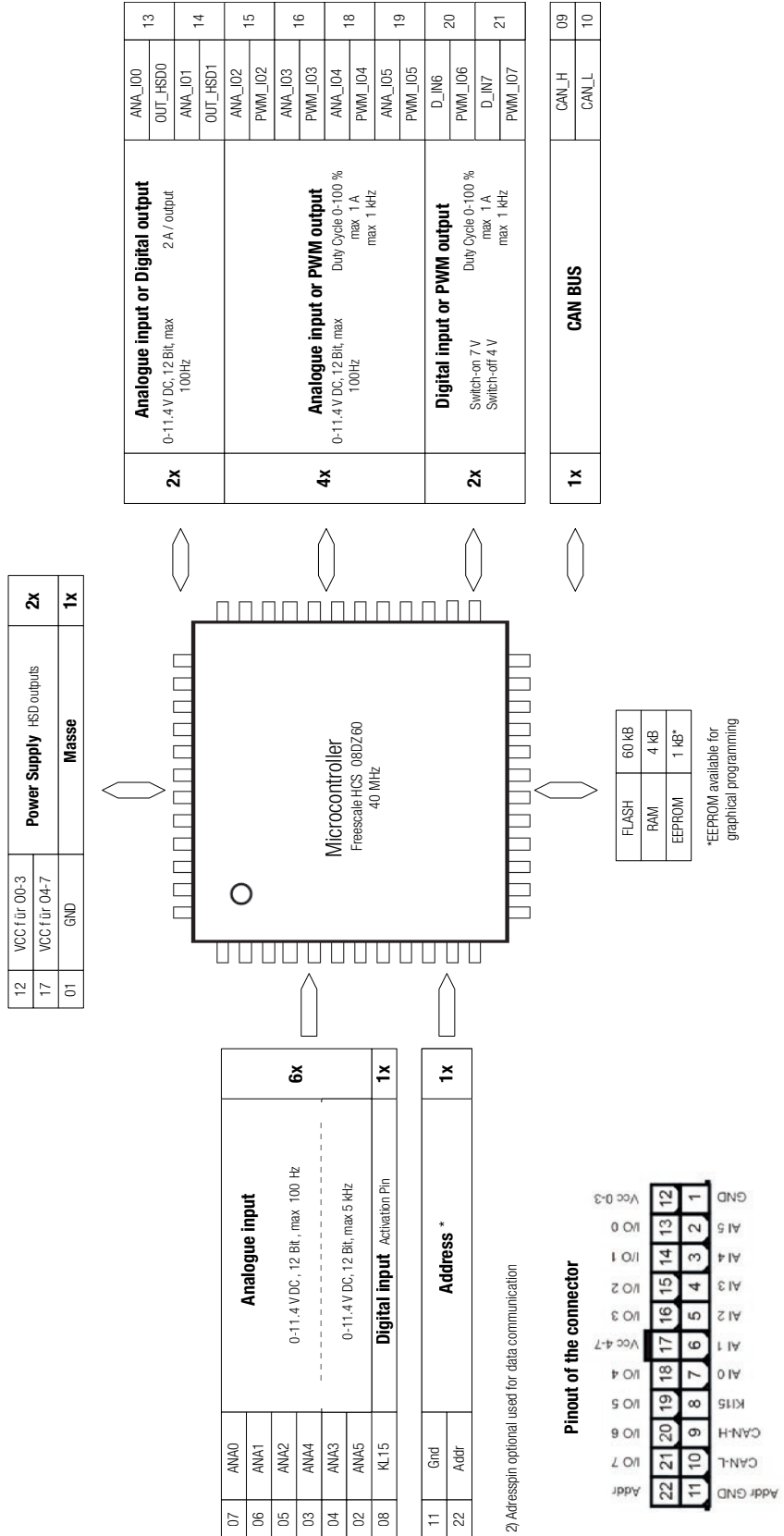

ICCS CAN I/O & 22P



Pin assignment

Connector ICS-97191, ICS-100710		
Pin	Description	Function
1	GND	Ground
2	ANA5	Analogue input 0-10 V max 5 kHz
3	ANA4	Analogue input 0-10 V
4	ANA3	Analogue input 0-10 V max 5 kHz
5	ANA2	Analogue input 0-10 V
6	ANA1	Analogue input 0-10 V
7	ANA0	Analogue input 0-10 V
8	KL15	Activation Pin
9	CAN H	CAN Bus High
10	CAN L	CAN Bus Low
11	Addr GND	Address GND
12	VCC for 00-3	Power Supply HSD output 0-3
13	ANA_I00	Analogue input 0-10 V
	OUT_HSD0	Digital output and Status output
14	ANA_I01	Analogue input 0-10 V
	OUT_HSD1	Digital output and Status output
15	ANA_I02	Analogue input 0-10 V
	OUT_HSD2	PWM output and Status output
16	ANA_I03	Analogue input 0-10 V
	OUT_HSD3	PWM output and Status output
17	VCC for 04-7	Power Supply HSD output 4-7
18	ANA_I04	Analogue input 0-10 V
	OUT_HSD4	PWM output and Status output
19	ANA_I05	Analogue input 0-10 V
	OUT_HSD5	PWM output and Status output
20	D_IN6	Digital input
	OUT_HSD6	PWM output and Status output
21	D_IN7	Digital input
	OUT_HSD7	PWM output and Status output
22	Addr	Single wire Address

Connector module

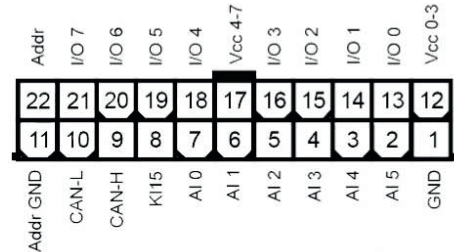

Dimensions

Wire harness version i.e. CAN I/O

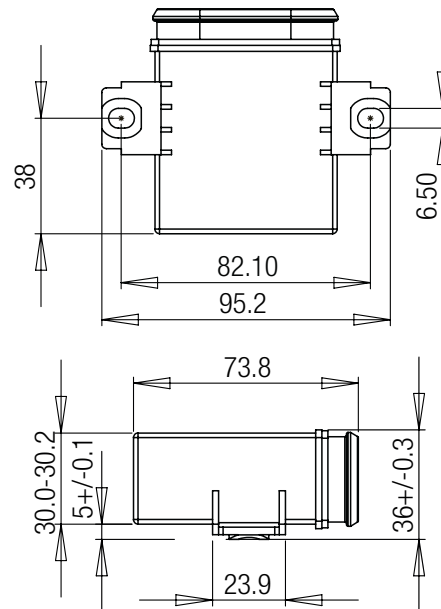

ICCS CAN I/O & 22P



Hardware Map

■ ICS-101976: ICCS CAN I/O Waterproof

B1	VCC for 00-3	Power Supply	HSD outputs	2x
B8	VCC for 04-7			
B6	GND	Ground		2x
C1				

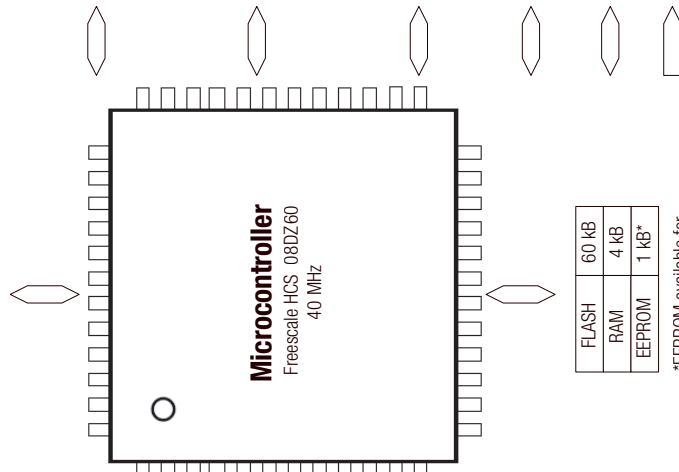

C7	ANA0	Analogue input	0-11.4 V DC / 0-20 mA, 12 Bit, max 30 Hz	6x
C6	ANA1			
C5	ANA2			
C4	ANA3			
C3	ANA4			
C2	ANA5			
C8	KL15	Digital input	Activation Pin	1x

Pinout of the connector



2x	Analogue input or Digital output 0-11.4 V DC, 12 Bit, max 100 Hz 2 A / output	ANA_I00 OUT_HSD0 ANA_I01 OUT_HSD1 ANA_I02 OUT_HSD2 ANA_I03 OUT_HSD3 ANA_I04 OUT_HSD4 ANA_I05 OUT_HSD5	A1 A2 A3 A4 A5 A6
4x	Analogue input or PWM output 0-11.4 V DC, 12 Bit, max 100 Hz Duty Cycle 0-100 % max 1 A max 1 kHz	D_IN6 OUT_HSD6 D_IN7 OUT_HSD7	A7 A8
2x	Digital input or PWM output Switch-on 7 V Switch-off 4 V Duty Cycle 0-100 % max 1 A max 1 kHz	CAN_H CAN_L	B2 B3
1x	CAN BUS	Opt. A Opt. B	B4 B5
1x	Reference Voltage 5V, max 500 mA	POWER	B7

FLASH	60 kB
RAM	4 kB
EEPROM	1 kB*

*EEPROM available for graphical programming

ICCS CAN I/O & 22P



Pin assignment

Connector ICS-101976		
Pin	Description	Function
A1	ANA_IO0	Analogue input 0-10 V
	OUT_HSD0	Digital output
A2	ANA_IO1	Analogue input 0-10 V
	OUT_HSD1	Digital output
A3	ANA_IO2	Analogue input 0-10 V
	OUT_HSD2	Digital / PWM output
A4	ANA_IO3	Analogue input 0-10 V
	OUT_HSD3	Digital / PWM output
A5	ANA_IO4	Analogue input 0-10 V
	OUT_HSD4	Digital / PWM output
A6	ANA_IO5	Analogue input 0-10 V
	OUT_HSD5	Digital / PWM output
A7	D_IN6	Digital input
	OUT_HSD6	Digital / PWM output
A8	D_IN7	Digital input
	OUT_HSD7	Digital / PWM output
B1	VCC for 00-3	Power Supply HSD output 0-3
B2	CAN H	CAN Bus High
B3	CAN L	CAN Bus Low
B4	Opt. A	Optional RS485-A
B5	Opt. B	Optional RS485-B
B6	GND	Ground
B7	VREF_OUT	5V Reference
B8	VCC for 04-7	Power Supply HSD output 4-7
C1	Addr GND	Address GND
C2	ANA5 / D_ANA5	Analogue / Frequency input 0-30 V
C3	ANA4 / D_ANA4	Analogue input 0-10 V
C4	ANA3 / D_ANA3	Analogue / Frequency input 0-10 V
C5	ANA2 / D_ANA2	Analogue input 0-10 V / 0-20 mA
C6	ANA1 / D_ANA1	Analogue input 0-10 V / 0-20 mA
C7	ANA0 / D_ANA0	Analogue input 0-10 V / 0-20 mA
C8	KL15	Activation Pin

Connector module

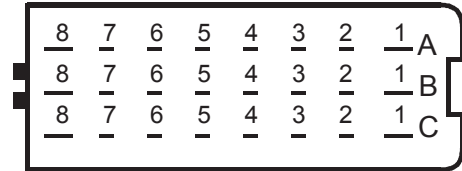

Dimensions

Wire harness version i.e. Waterproof CAN I/O

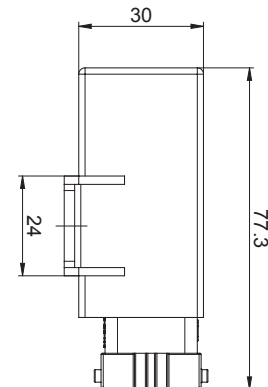
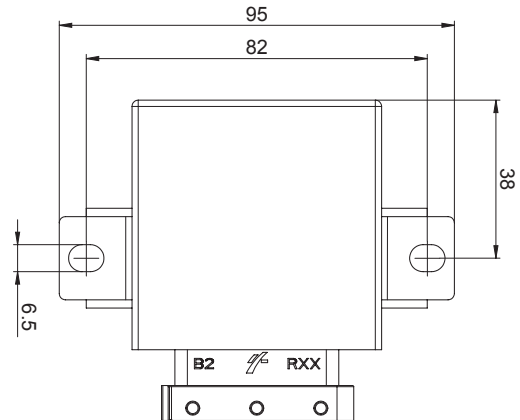
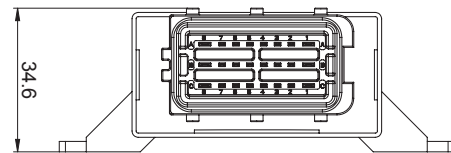

ICCS

CAN I/O & 22P

Order information

Available references	Part number WE ICS
ICCS CAN I/O Hardware Bootloader	ICS-95065
ICCS CAN I/O Software Bootloader	ICS-95114
ICCS CAN I/O Software Bootloader Diode on PWM output	ICS-100710
ICCS CAN I/O 2 x RPM 6 x PWM Software Bootloader	ICS-97191
ICCS CAN I/O +5 VREF Software Bootloader	ICS-97212
ICCS CAN I/O Waterproof	ICS-101976
ICCS 22P CAN Controller	ICS-100514

Mating connector (CAN I/O and 22P)	Part number WE eiSos
Housing: Female Dual Row Plug WR-MPC4	649 022 113 322
Crimp contact: WR-MPC4, AWG 16	649 005 137 22
Crimp contact: WR-MPC4, AWG 24-18	649 006 137 22
Crimp contact: WR-MPC4, AWG 28-22	649 007 137 22

For 100 pieces packages, please add „DEC“ at the end of the reference.

Mating connector (CAN I/O WP)	Part number FCI
Housing: FCI SICMA: 24 Pins (18 x 1.5 mm + 6 x 2.8 mm), female	211 PC249S0005
FCI Locking cam	211 A247 001
Terminals: SICMA-3 1.5 terminal female, 0.34...0.75 mm ²	211 CC2S1160
Terminals: SICMA-3 1.5 terminal female, 1.00...2.00 mm ²	211 CC2S2160
Terminals: SICMA-3 2.8 terminal female, 0.35...0.75 mm ²	211 CC3S1160
Terminals: SICMA-3 2.8 terminal female, 1.0...2.5 mm ²	211 CC3S2160
Plug seals for unused contact chambers	210 A015019



For more information visit us
at www.we-online.com or call
+49 7940 9810-0.

Würth Elektronik ICS GmbH & Co. KG
Intelligent Power & Control Systems

Gewerbepark Waldzimmern
Würthstraße 1
74676 Niedernhall
Tel. +49 7940 9810-0
Fax +49 7940 9810-1099
ics@we-online.de
www.we-online.com

This item is a standard product, please consider the relevant datasheet notes.
The user is responsible for the product's functionality in its purposed system environment.